



*MT80 2D Mini Imager+MTD20 Decoder Board, Integration Guide, V1.0*

---

**MT80**  
(2D Mini Imager)

**MTD20**  
(Decoder Board)

## **Integration Guide**

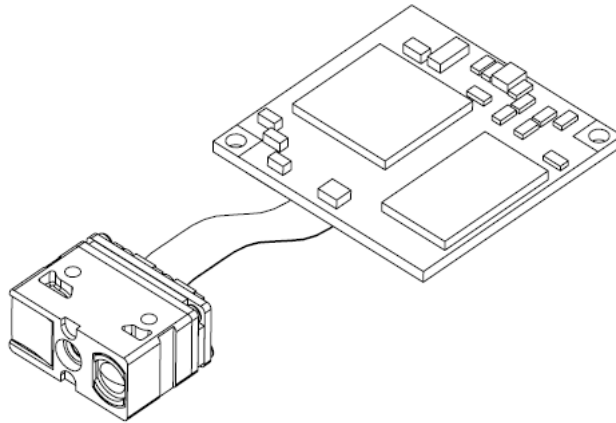



## TABLE OF CONTENTS

<b>1. INTRODUCTION .....</b>	<b>1</b>
<b>1-1. Block Diagram .....</b>	<b>1</b>
<b>1-2. Electric Interface.....</b>	<b>2</b>
<b>1-2-1. Pin Assignment .....</b>	<b>2</b>
<b>2. SPECIFICATIONS .....</b>	<b>6</b>
<b>2-1. Introduction.....</b>	<b>6</b>
<b>2-2. Technical Specifications .....</b>	<b>6</b>
<b>2-3. Interface.....</b>	<b>9</b>
<b>2-3-1. UART Interface .....</b>	<b>9</b>
<b>2-3-2. USB HID Interface.....</b>	<b>9</b>
<b>2-3-3. USB VCP Interface .....</b>	<b>9</b>
<b>2-4. Operation Method .....</b>	<b>10</b>
<b>2-5. Mechanical Dimension .....</b>	<b>10</b>
<b>2-6. Connector Specification .....</b>	<b>11</b>
<b>3. INSTALLATION .....</b>	<b>12</b>
<b>3-1. Electrostatic Discharge Cautions.....</b>	<b>12</b>
<b>3-2. Mechanical Dimension .....</b>	<b>12</b>
<b>3-3. Window Materials .....</b>	<b>13</b>
<b>3-4. Window Specifications.....</b>	<b>14</b>
<b>3-5. Window Care .....</b>	<b>15</b>
<b>4. REGULATIONS .....</b>	<b>15</b>
<b>5. DEVELOPMENT KIT .....</b>	<b>16</b>
<b>6. VERSION HISTORY .....</b>	<b>17</b>

# 1. INTRODUCTION

The MT80 Mini Imager+MTD20 Decoder Board is designed for 1D Barcode and QR Code scanning with easy integration. Due to its small size MT80+MTD20 is ideal for integration into data terminals and other small mobile devices.

The MT80 Mini Imager consists of 1 illumination LED, 1 aimer LED and a high-quality image sensor with a microprocessor on MTD20 Decoder Board that contains powerful firmware to control all aspects of operations and enable communication with the host system over the standard set of communication interfaces.

Two interfaces, UART & USB, are available. UART interface communicates with the host system over TTL-level RS232 communication; USB interface emulates a USB HID Keyboard device and communicates with the host system over USB.

## 1-1. Block Diagram

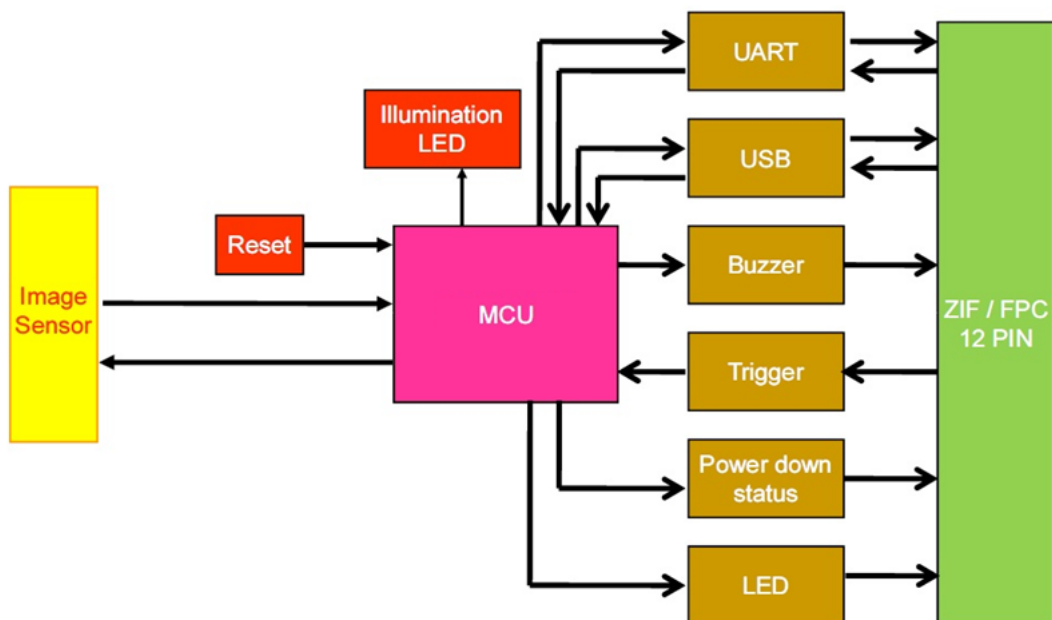

## 1-2. Electric Interface

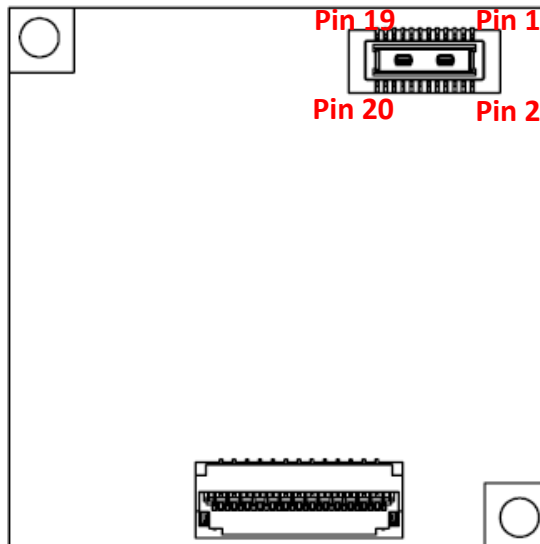

### 1-2-1. Pin Assignment

(Top View of MTD20 Decoder Board)

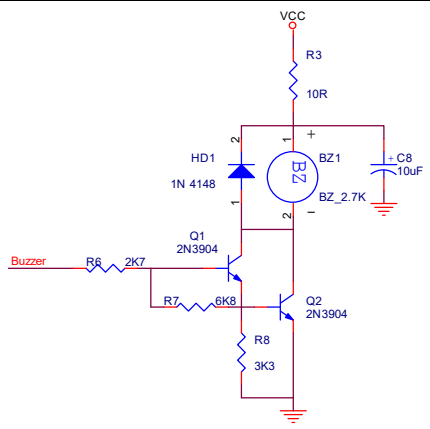
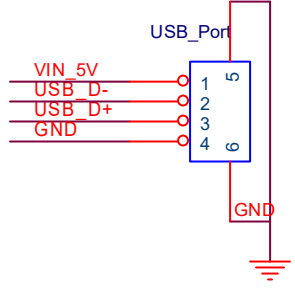
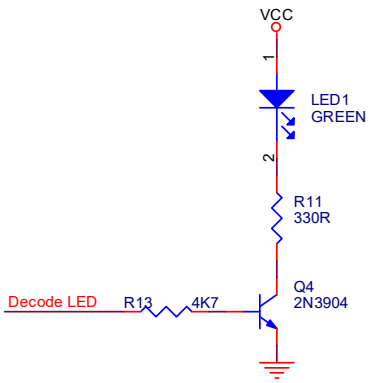
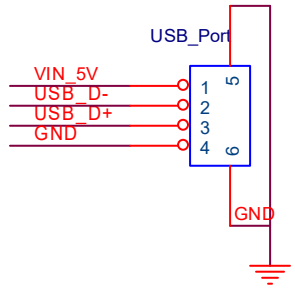

Pin#	UART	USB	I/O	Description	Schematic Example
1	nPWRDWN	nPWRDWN	Output	When nPWRDWN is active low, MTD20 is in sleep mode.	
2	GND	GND	-----	Power and signal ground.	

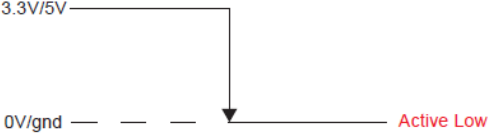
Pin#	UART	USB	I/O	Description	Schematic Example
3	Buzzer PWN	Buzzer PWN	Output	Active High: it indicates the status of Power-Up or a successful barcode decoded.  PWM controlled signal can be used to drive an external buzzer for a successful barcode decoded (Good Read).	
4	-----	USB_D+	Bidirectional	USB Differential Signal Transmission (USB D+)	
5	Good Read	Good Read	Output	Active High, it indicates the status of Power-Up or a successful barcode decoded (Good Read).	
6	-----	USB_D-	Bidirectional	USB Differential Signal Transmission (USB D-)	

Pin#	UART	USB	I/O	Description	Schematic Example																														
7	nWAKE	nWAKE	Input	When MTD20 is in sleep mode, active low to wake up.																															
8	GND	GND	-----	Power and signal ground.																															
9	Trigger Input	Trigger Input	Input	High: Power-up/Standby Low: Scanning Operation  <b>*Warning:</b> 1. Pull low at power-up will prompt the scan engine into firmware update mode.	 <p>Once trigger is pressed (pull low), scanning operation continues until a barcode is successfully decoded or the trigger is released (pull high). To proceed to the next scanning operation, release (pull high) first and press (pull low) the trigger again.</p>																														
10	RTS	-----	Output	When Handshaking is enabled, MT80 requests permission from host to transmit data on TXD line.	<table border="1" style="margin-left: auto; margin-right: auto;"> <thead> <tr> <th colspan="6">RS232 IC</th> </tr> </thead> <tbody> <tr> <td>TXD</td><td>11</td><td>T11</td><td>R10</td><td>14</td><td>RS232-TXD</td> </tr> <tr> <td>RTS</td><td>10</td><td>T21</td><td>R20</td><td>7</td><td>RS232-RTS</td> </tr> <tr> <td>RXD</td><td>12</td><td>T10</td><td>R11</td><td>13</td><td>RS232-RXD</td> </tr> <tr> <td>CTS</td><td>9</td><td>T20</td><td>R21</td><td>8</td><td>RS232-CTS</td> </tr> </tbody> </table> <p style="text-align: center;">Sipex® Vendor P/N: SP232ACT</p>	RS232 IC						TXD	11	T11	R10	14	RS232-TXD	RTS	10	T21	R20	7	RS232-RTS	RXD	12	T10	R11	13	RS232-RXD	CTS	9	T20	R21	8	RS232-CTS
RS232 IC																																			
TXD	11	T11	R10	14	RS232-TXD																														
RTS	10	T21	R20	7	RS232-RTS																														
RXD	12	T10	R11	13	RS232-RXD																														
CTS	9	T20	R21	8	RS232-CTS																														
11	VDD_3V3_IN	VDD_3V3_IN	-----	Supply voltage input. Must always be connected to 3.3V power supply.																															
12	CTS	-----	Input	When Handshaking is enabled, host authorizes MT80 to transmit data on TXD line.	<table border="1" style="margin-left: auto; margin-right: auto;"> <thead> <tr> <th colspan="6">RS232 IC</th> </tr> </thead> <tbody> <tr> <td>TXD</td><td>11</td><td>T11</td><td>R10</td><td>14</td><td>RS232-TXD</td> </tr> <tr> <td>RTS</td><td>10</td><td>T21</td><td>R20</td><td>7</td><td>RS232-RTS</td> </tr> <tr> <td>RXD</td><td>12</td><td>T10</td><td>R11</td><td>13</td><td>RS232-RXD</td> </tr> <tr> <td>CTS</td><td>9</td><td>T20</td><td>R21</td><td>8</td><td>RS232-CTS</td> </tr> </tbody> </table> <p style="text-align: center;">Sipex® Vendor P/N: SP232ACT</p>	RS232 IC						TXD	11	T11	R10	14	RS232-TXD	RTS	10	T21	R20	7	RS232-RTS	RXD	12	T10	R11	13	RS232-RXD	CTS	9	T20	R21	8	RS232-CTS
RS232 IC																																			
TXD	11	T11	R10	14	RS232-TXD																														
RTS	10	T21	R20	7	RS232-RTS																														
RXD	12	T10	R11	13	RS232-RXD																														
CTS	9	T20	R21	8	RS232-CTS																														

Pin#	UART	USB	I/O	Description	Schematic Example
13	VDD_3V3_IN	VDD_3V3_IN	-----	Supply voltage input. Must always be connected to 3.3V power supply.	
14	TXD	-----	Output	UART TTL data output.	<p>Sipex® Vendor P/N: SP232ACT</p>
15	VDD_3V3_IN	VDD_3V3_IN	-----	Supply voltage input. Must always be connected to 3.3V power supply.	
16	RXD	-----	Input	UART TTL data input.	<p>Sipex® Vendor P/N: SP232ACT</p>
17	IF_SEL	IF_SEL	Input	High: UART Low: USB	
18	GND	GND	-----	Power and signal ground.	
19	GND	GND	-----	Power and signal ground.	
20	GND	GND	-----	Power and signal ground.	



## 2. SPECIFICATIONS

### 2-1. Introduction

This chapter provides technical specifications of the MT80+MTD20. Operating method, scanning range and scan angle are also presented.

### 2-2. Technical Specifications

Optic & Performance	
<b>Light Source</b>	3000K CCT white LED
<b>Aiming</b>	625nm visible red LED dot aimer
<b>Sensor</b>	640 x 480 pixels
<b>Scan Rate</b>	30 frames/ sec
<b>Resolution</b>	5mil/ 0.125mm (Code 39)
<b>Field of View</b>	Horizontal 45° Vertical 33°
<b>Scan Angle</b>	Pitch Angle $\pm 60^\circ$ Skew Angle $\pm 30^\circ$ Roll Angle 360°
<b>Print Contrast Ratio</b>	30%
<b>Width of Field</b>	70mm (13Mil Code39)
<b>Typical Depth Of Field</b> (Environment: 800 lux)	5 Mil Code39: 32 ~ 71mm
	10 Mil Code39: 24 ~ 156mm
	15 Mil Code39: 36 ~ 229mm
	13 Mil UPC/ EAN: 35 ~ 172mm
	10 Mil QR Code: 29 ~ 74mm
	15 Mil QR Code: 25 ~ 129mm
	40 Mil QR Code: 53 ~ 297mm
<b>Guaranteed Depth Of Field</b> (Environment: 800 lux)	5 Mil Code39: 35 ~ 70mm
	10 Mil Code39: 35 ~ 115mm
	15 Mil Code39: 45 ~ 165mm
	13 Mil UPC/ EAN: 45 ~ 140mm
	10 Mil QR Code: 40 ~ 60mm
	15 Mil QR Code: 35 ~ 105mm





*MT80 2D Mini Imager+MTD20 Decoder Board, Integration Guide, V1.0*

	40 Mil QR Code: 70 ~ 200mm
<b>Physical Characteristics</b>	
<b>Dimension</b>	MT80 Imager : W14 x L10 x H7 mm MTD20 Decoder Board : W25 x L25 x H2 mm
<b>Weight</b>	MT80 Imager : 1g MTD20 Decoder Board : 2.7g
<b>Color</b>	Black
<b>Material</b>	ABS
<b>Connector</b>	Imager to Decoder board : 25pin ZIF (pitch=0.3mm) Decoder Board to Host : 20pin Board-to-Board Connector (pitch=0.4mm)
<b>Cable</b>	MT80 Imager to MTD20 Decoder: 25pin flex cable (pitch=0.3mm)
<b>Electrical</b>	
<b>Operation Voltage</b>	3.3VDC $\pm$ 5%
<b>Working Current</b>	< 300 mA
<b>Standby Current</b>	< 200 mA
<b>Idle Current (Sleep Mode)</b>	< 2 mA
<b>Surge Current</b>	< 500 mA
<b>Connectivity</b>	
<b>Interface</b>	UART (TTL-level RS232)
	USB (HID Keyboard)
	USB (Virtual COM)
<b>User Environment</b>	
<b>Operating Temperature</b>	0°C ~ 50°C
<b>Storage Temperature</b>	-20°C ~ 60°C
<b>Humidity</b>	0% ~ 95%RH (Non-condensing)
<b>Drop Durability</b>	1.5M
<b>Ambient Light</b>	100,000 Lux (Sunlight)



MT80 2D Mini Imager+MTD20 Decoder Board, Integration Guide, V1.0

<p><b>1D Symbologies</b></p>	<p>UPC-A/ UPC-E          EAN-8/ EAN-13          Matrix 2 of 5          China Postal Code (Toshiba Code)          Industrial 2 of 5          Interleaved 2 of 5          Standard 2 of 5 (IATA Code)          Codabar          Code 11          Code 32          Standard Code 39          Full ASCII Code 39          Code 93          Code 128          EAN/ UCC 128 (GS1-128)          MSI/ UK Plessey Code          Telepen Code          GS1 Databar</p>
<p><b>2D Symbologies</b></p>	<p>QR Code          Micro QR Code          PDF417          Data Matrix          Aztec</p>
<p><b>Regulatory</b></p>	
<p><b>ESD</b></p>	<p>Functional after 4KV contact, 8KV air discharge  <i>(It requires housing that is designed for ESD protection and stray from electric fields.)</i></p>
<p><b>EMC</b></p>	<p>FCC – Part15 Subpart B (Class B)          CE – EN55024, EN55032</p>
<p><b>Safety Approval</b></p>	<p>IEC 62471 (Group 1)</p>
<p><b>Environmental</b></p>	<p>WEEE, RoHS 2.0</p>



## 2-3. Interface

### 2-3-1. UART Interface

Below are default communication protocols:

**Baud rate:** 9600

**Data Bits:** 8

**Parity:** None

**Stop Bit:** 1

**Handshaking:** None

**Flow Control Timeout:** None

**ACK/NAK:** OFF

**BCC:** OFF

**Interface Configuration Barcode:**

. C002\$



**UART**

### 2-3-2. USB HID Interface

**Interface Configuration Barcode:**

. C008\$



**USB HID**

### 2-3-3. USB VCP Interface

**Interface Configuration Barcode:**

. C006\$



**USB VCP**

## 2-4. Operation Method

1. At power-up, the MTD20 sends the Power-Up signals over Buzzer and LED pins as an indication that the MTD20 enters **Standby Mode** and is ready for operation.
2. Once the MTD20 triggered by either hardware or software method, MT80 will emit a beam of light which is aligned with the sensor's field of view.
3. The area image sensor captures the image of barcode and produces an analog waveform, which is sampled and analyzed by the decoder firmware running on the MTD20.
4. Upon a successful barcode decoded, the MT80 turns off the illumination LEDs, with MTD20 sending the Good Read signals over Buzzer and LED pins and transmitting the decoded data to the host.

## 2-5. Mechanical Dimension

(Unit = mm)

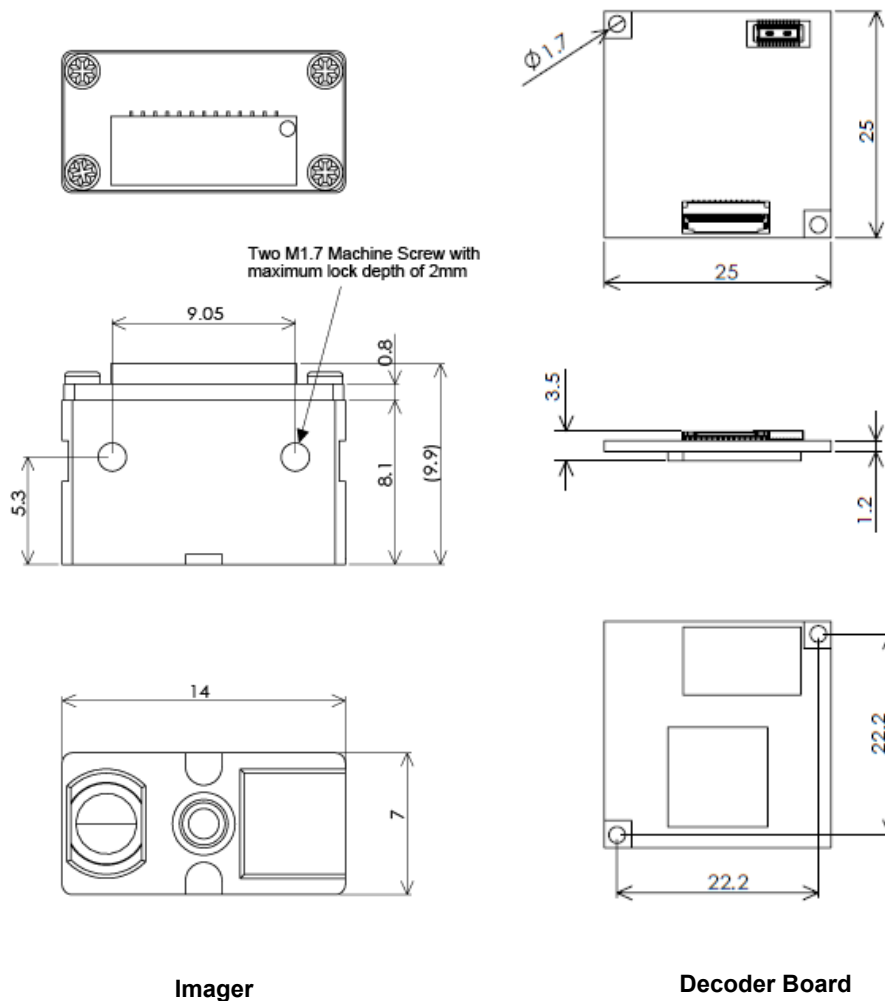

Imager

Decoder Board

## 2-6. Connector Specification

Below is the recommended 20-pin 0.4-pitch board-to-board connector on the host side.

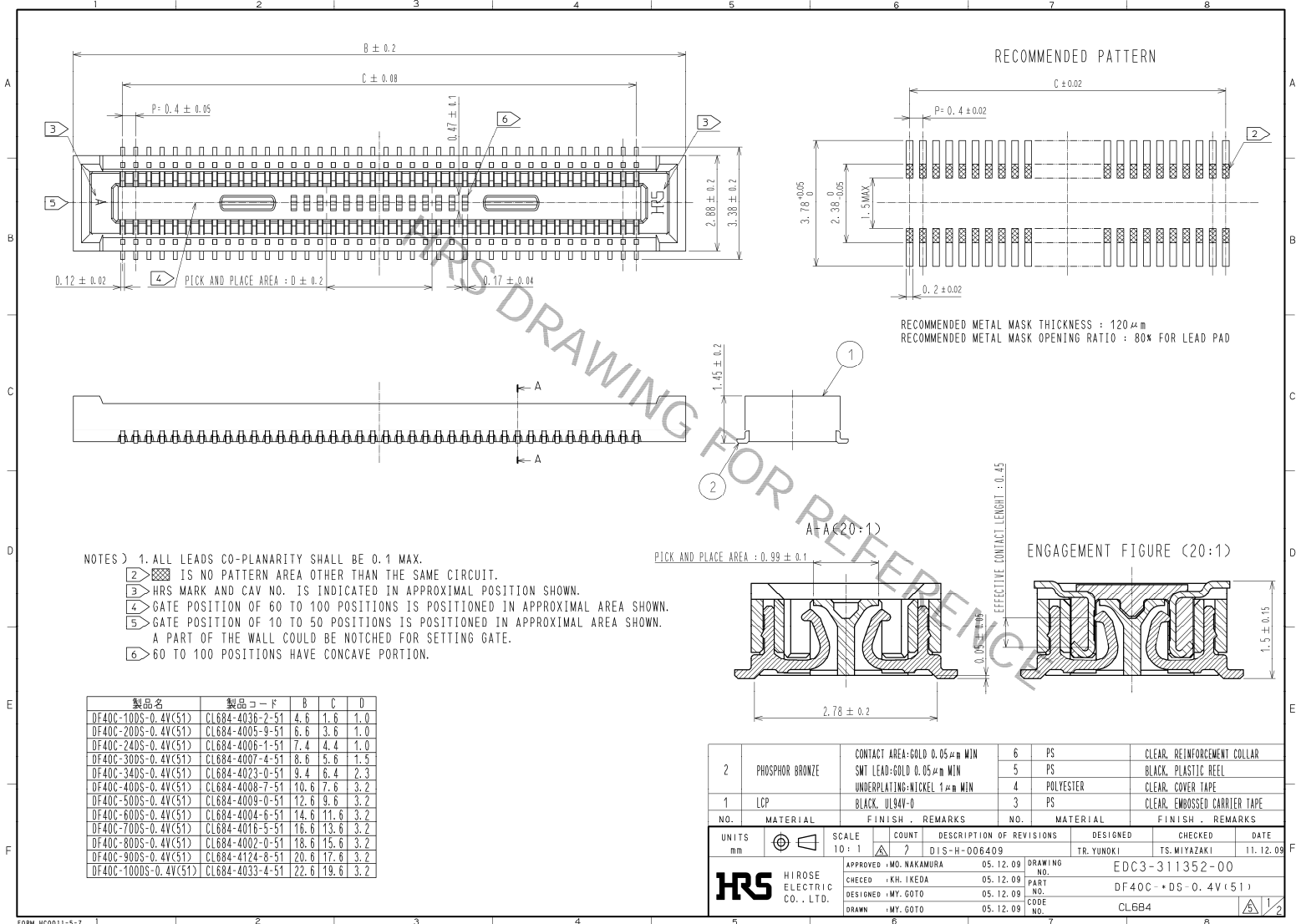



## **3. INSTALLATION**

The scan engine is designed specifically for integration into customer's housing for OEM applications. However, the scan engine's performance will be adversely affected or permanently damaged when mounted into an unsuitable enclosure.

**Warning:** The limited warranty is void if the following recommendations are not adhered to when mounting the scan engine.

### **3-1. Electrostatic Discharge Cautions**

All scan engines are shipped in ESD protective packaging due to the sensitive nature of the exposed electrical components.

1. ALWAYS use grounding wrist straps and a grounded work area when unpacking and handling the scan engine.
2. Mount the scan engine in a housing that is designed for ESD protection and stray electric fields.

### **3-2. Mechanical Dimension**

When securing the scan engine by utilizing the machine screws:

1. Leave sufficient space to accommodate the maximum size of the scan engine.
2. Do not exceed 1kg-cm (0.86 lb-in) of torque when securing the scan engine to the host.
3. Use safe ESD practices when handling and mounting the scan engine.



### 3-3. Window Materials

Following are descriptions of three popular window materials:

1. Poly-methyl Methacrylic (PMMA)
2. Allyl Diglycol Carbonate (ADC)
3. Chemically tempered float glass

#### Cell Cast Acrylic (ASTM: PMMA)

Cell cast Acrylic, or Poly-methyl Methacrylic is fabricated by casting acrylic between two precision sheet of glass. This material has very good optical quality, but is relatively soft and susceptible to attack by chemicals, mechanical stress and UV light. It is strongly recommended to have acrylic hard-coated with Polysiloxane to provide abrasion resistance and protection from environmental factors. Acrylic can be laser-cut into odd shapes and ultrasonically welded.

#### Cell Cast ADC, Allyl Diglycol Carbonate (ASTM: ADC)

Also known as CR-39™, ADC, a thermal setting plastic widely used for plastic eyeglasses, has excellent chemical and environmental resistance. It also has an inherently moderate surface hardness and therefore does not require hard-coating. This material cannot be ultrasonically welded.

#### Chemically Tempered Float Glass

Glass is a hard material which provides excellent scratch and abrasion resistance. However, un-annealed glass is brittle. Increased flexibility strength with minimal optical distortion requires chemical tempering. Glass cannot be ultrasonically welded and is difficult to cut into odd shapes.

Property	Description
Spectral Transmission	85% minimum from 635 to 690 nanometers
Thickness	< 1 mm
Coating	Both sides to be anti-reflection coated to provide 1% maximum reflectivity from 635 to 690 nanometers at nominal window tilt angle. An anti-reflection coating can reduce the light that is reflected back to the host case. Coatings will comply with the hardness adherence requirements of MIL-M-13508.

### 3-4. Window Specifications

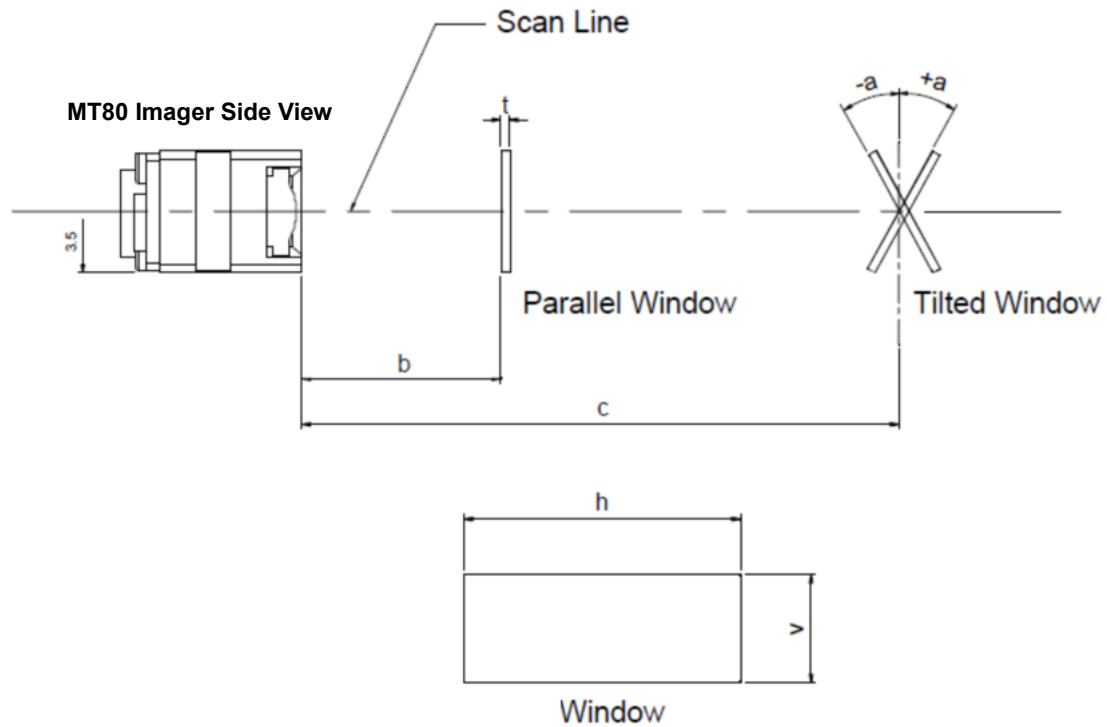

Window Specifications for MT80 Integration					
Distance	Tilt Angle (a)		Minimum Window Size		
			Horizontal (h)	Vertical (v)	Thickness (t)
< 0.5 mm (b)	0	0	18 mm	7 mm	< 1 mm
10 mm (c)	> +20°	< -20°	25 mm	15 mm	
20 mm (c)	> +17°	< -17°	35 mm	25 mm	
30 mm (c)	> +15°	< -15°	50 mm	40 mm	





### **3-5. Window Care**

In the aspect of window, the performance of MT80 will be reduced due to any kind of scratch. Thus, reducing the damage of window, there are few things have to be noticed.

1. Avoid touching the window as much as possible.
2. When cleaning the window surface, please use non-abrasive cleaning cloth, and then gently wipe the host window with the cloth that is already sprayed with glass cleaner.

## **4. REGULATIONS**

The MT80 scan engine conforms to the following regulations:

1. Electromagnetic Compliance – CE EN55024, EN55032
2. Electromagnetic Interference – FCC Part15 Subpart B (Class B)
3. Photobiological Safety – IEC 62471 (Exempt Group)
4. Environmental Regulations – RoHS 2.0, WEEE

## 5. DEVELOPMENT KIT

MARSON MB110 Demo Kit (P/N: 11B0-A020000) enables the development of products and systems using the MT80+MTD20 on the MS Windows OS platform. Besides the Multi I/O board (P/N: 21B0-204A000), the MB110 Demo Kit also provides the software and hardware tools required for testing the MT80+MTD20 applications before integrating it into the host device. Please contact your sales representative for ordering information.

### MB110 Multi I/O Board (P/N: 21B0-204A000)

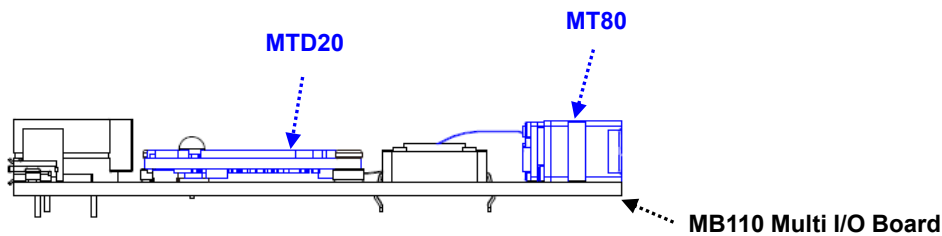
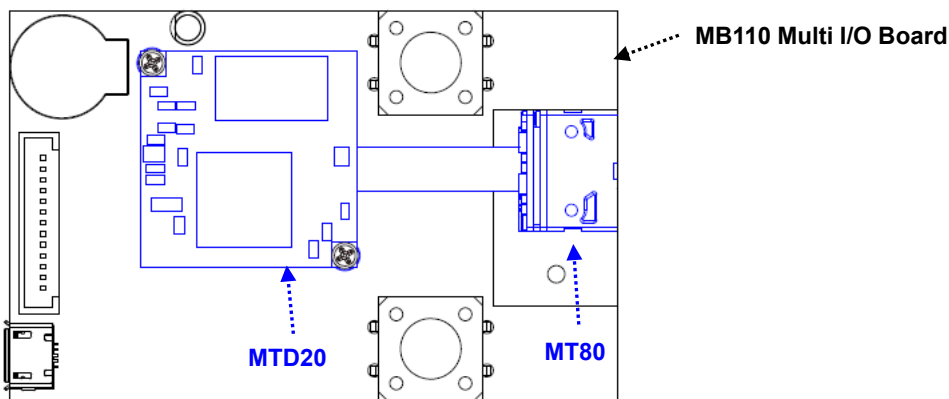

### MB110 Demo Kit Accessories

O: Supported X: Not Supported

Interface	RS232 (UART)	USB HID	USB VCP
<b>Cable</b>			
External Y-cable (P/N: 7090-1583A00)	o	o	o
Internal Y-cable (P/N: 5300-1315X00)	o	o	o
Micro USB Cable (P/N: 7005-9892A50)	x	o	o



## 6. VERSION HISTORY

Rev.	Date	Description	Issued	Checked
1.0	2017.11.24	Initial Release	Shaw	Kenji & Hus

### **Marson Technology Co., Ltd.**

9F., 108-3, Mincyuan Rd., Sindian Dist., New Taipei City, Taiwan

TEL: 886-2-2218-1633

FAX: 886-2-2218-6638

E-mail: [info@marson.com.tw](mailto:info@marson.com.tw)

Web: [www.marsontech.com](http://www.marsontech.com)