

MB100 Multi I/O Board Integration Guide

MT40
MT40W
MT30

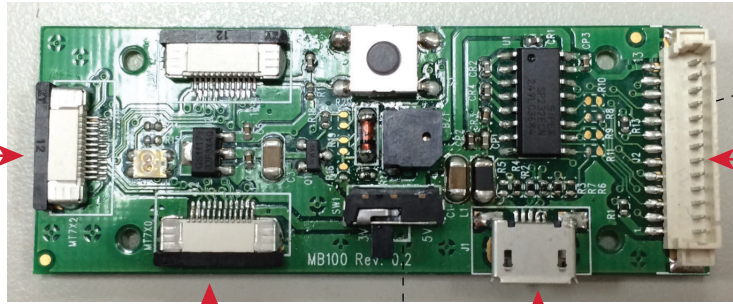

MT10
MT780
MT15
MT84G

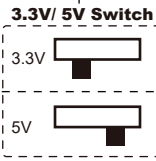

13-pin Connector

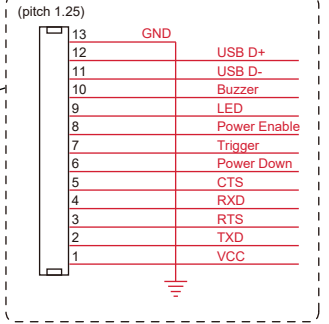

Interface/Cable Matrix

O: Supported X: Not Supported

Cable \ Interface	RS232	USB HID	USB VCP*
External Y-cable (P/N: 7090-1583A00)	O	O	O
Micro USB cable (P/N: 7005-9892A50)	X	O	O

*Note: For VCP driver please visit our website (www.marson.com.tw) for the latest documentation and downloads.

External Y-cable (P/N: 7090-1583A00)

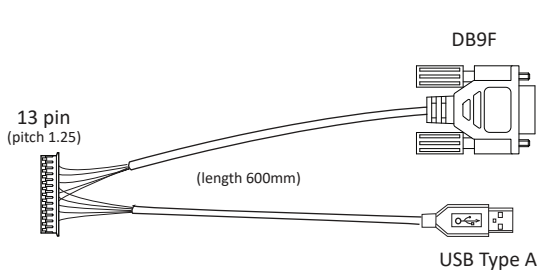

D-sub 9 Female Connector

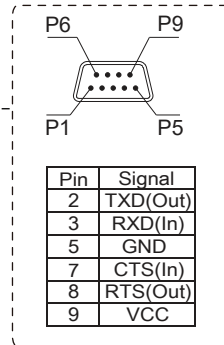

*Note: Power supply can be provided by the USB cable or directly from PIN 9 of the DB9F connector.

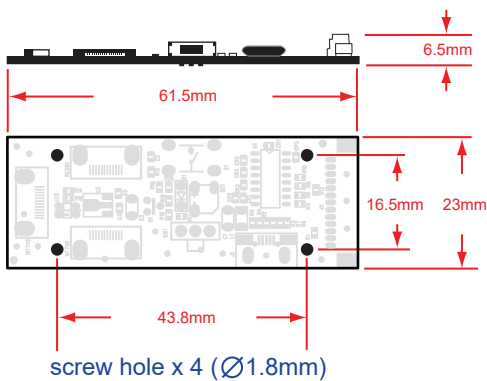

MB100 Multi I/O Board (P/N: 21A0-204A000)



Scan Engine Voltage

Voltage	3.3V	3.3~5V
Scan Engine	MT10	MT40
	MT780	MT40W
	MT30	
	MT15	
	MT84G	

Scan Engine Interface Configuration Table

Firmware Type	Configuration Method	Interface <small>See Interface/Cable Matrix on the back page for cable connection.</small>	Scan Engine & Firmware Version						
			MT40	MT40W	MT30	MT780	MT10	MT15	
Standard	1. Configurable by scanning barcodes 2. Configured by EzU* on PC 3. Supports hardware trigger only. *Available for download from our website. (www.marson.com.tw)	.C002\$  UART <small>MB100 converts engine's UART signals from TTL into RS232 levels.</small>	SM3-k-1.XX SM3-k-2.XX HM3-k-X.XX.R	SM3-k-1.XX SM3-k-2.XX HM3-k-X.XX.R	SM3-k-2.XX	SM3-e-X.XX HM3-e-X.XX HM3-e-X.XX.R	SM3-d-X.XX HM3-d-X.XX.R	SM0-a-X.XX	
		.C008\$  USB HID	SM3-k-1.XX SM3-k-2.XX HM3-k-X.XX.R	SM3-k-1.XX SM3-k-2.XX HM3-k-X.XX.R	SM3-k-2.XX	SM3-e-X.XX HM3-e-X.XX HM3-e-X.XX.R	SM3-d-X.XX HM3-d-X.XX.R		
		.C006\$  USB VCP <small>VCP driver is available on our website.</small>	SM3-k-1.XX SM3-k-2.XX HM3-k-X.XX.R	SM3-k-1.XX SM3-k-2.XX HM3-k-X.XX.R	SM3-k-2.XX	SM3-e-X.XX HM3-e-X.XX HM3-e-X.XX.R	SM3-d-X.XX HM3-d-X.XX.R		
Command Mode	1. Configurable by commands from host 2. FW with .CMD suffix configured by BEO* on PC; FW without suffix configured by EzU* on PC. 3. Supports both hardware and software trigger. *Available for download from our website. (www.marson.com.tw)	UART <small>MB100 converts engine's UART signals from TTL into RS232 levels.</small>	SM3-k-1.XX.CMD SM3-k-2.XX HM3-k-X.XX.R	SM3-k-1.XX.CMD SM3-k-2.XX HM3-k-X.XX.R	SM3-k-2.XX	SM3-e-X.XX.CMD HM3-e-X.XX HM3-e-X.XX.R	SM3-d-X.XX.CMD HM3-d-X.XX.R	SM0-a-X.XX	
		USB VCP <small>VCP driver is available on our website.</small>	SM3-k-2.XX HM3-k-X.XX.R	SM3-k-2.XX HM3-k-X.XX.R	SM3-k-2.XX	HM3-e-X.XX HM3-e-X.XX.R	HM3-d-X.XX.R		

*Firmware version information can be found on scan engine's box or product label.