

MT82Ag (2D Scan Engine)

Integration Guide

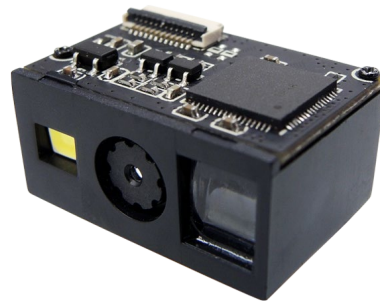

TABLE OF CONTENTS

1. INTRODUCTION	1
1-1. Block Diagram	1
1-2. Electric Interface	2
1-2-1. Pin Assignment	2
1-2-2. Electric Characteristics	5
2. SPECIFICATIONS	6
2-1. Introduction	6
2-2. Technical Specifications	6
2-3. Interface	8
2-3-1. UART Interface	8
2-3-2. USB HID Interface	8
2-3-3. USB VCP Interface	8
2-4. Operation Method	9
2-5. Mechanical Dimension	9
2-6. Connector Specification	10
3. INSTALLATION	11
3-1. Electrostatic Discharge Cautions	11
3-2. Mechanical Dimension	11
3-3. Window Materials	12
3-4. Window Placement	13
3-5. Window Size	13
3-6. Window Care	13
4. REGULATIONS	14
5. DEVELOPMENT KIT	15
6. PACKAGING	15
7. VERSION HISTORY	17

1. INTRODUCTION

MT82Ag One-piece Compact 2D Scan Engine provides snappy scanning performance at a competitive cost and compact form factor. With its all-in-one design, MT82Ag 2D scan engine can be easily integrated with specific applications such as access control, lottery kiosk and consumer electronics.

The MT82Ag 2D Scan Engine consists of 1 illumination LED, 1 aimer LED and a high-quality image sensor with a microprocessor that contains powerful firmware to control all aspects of operations and enable communication with the host system over the standard set of communication interfaces.

Two interfaces, UART & USB, are available. UART interface communicates with the host system over TTL-level RS232 communication; USB interface emulates a USB HID Keyboard or Virtual COM port device and communicates with the host system over USB.

1-1. Block Diagram

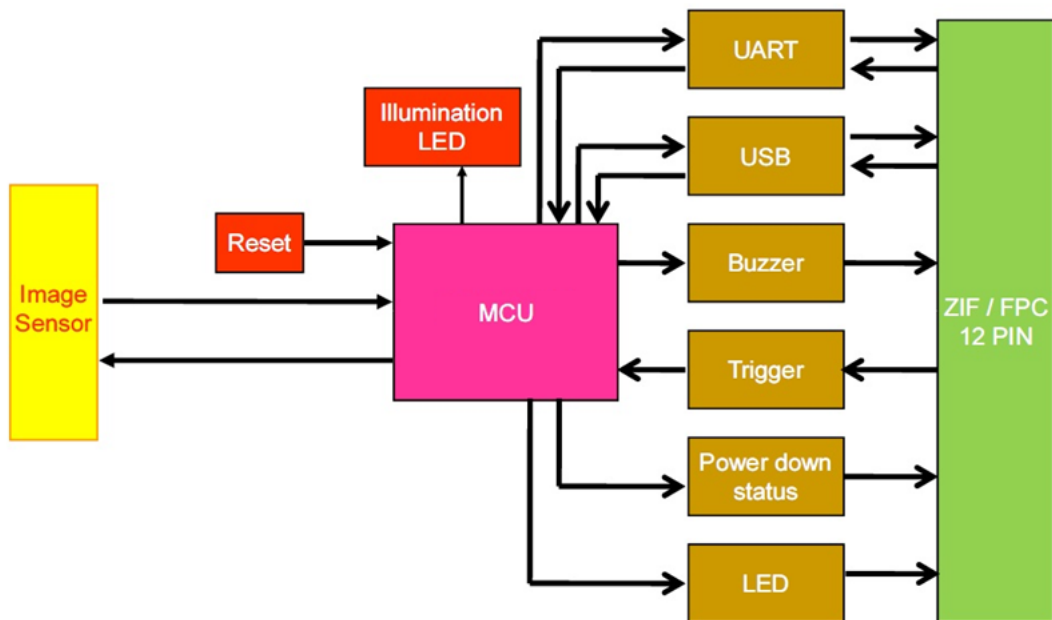



1-2. Electric Interface

1-2-1. Pin Assignment

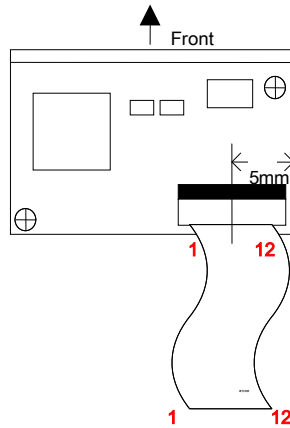
(Top View of MT82Ag)

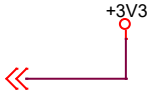

(Contact points of FFC Cable facing downward)

Pin#	UART	USB	I/O	Description	Schematic Example																				
1	NC	NC	-----	Floating																					
2	VCC	VCC	-----	Supply voltage input. Must always be connected to 3.3V power supply.																					
3	GND	GND	-----	Power and signal ground.																					
4	RXD	RXD	Input	UART TTL data input.	<div style="text-align: center;"> RS232 IC </div> <table border="0" style="width: 100%; border-collapse: collapse;"> <tr> <td style="border-right: 1px solid black; padding: 2px;">TXD 11</td> <td style="padding: 2px;">T11</td> <td style="padding: 2px;">R10</td> <td style="padding: 2px;">14</td> <td style="border-left: 1px solid black; padding: 2px;">RS232-TXD</td> </tr> <tr> <td style="border-right: 1px solid black; padding: 2px;">RTS 10</td> <td style="padding: 2px;">T21</td> <td style="padding: 2px;">R20</td> <td style="padding: 2px;">7</td> <td style="border-left: 1px solid black; padding: 2px;">RS232-RTS</td> </tr> <tr> <td style="border-right: 1px solid black; padding: 2px;">RXD 12</td> <td style="padding: 2px;">T10</td> <td style="padding: 2px;">R11</td> <td style="padding: 2px;">13</td> <td style="border-left: 1px solid black; padding: 2px;">RS232-RXD</td> </tr> <tr> <td style="border-right: 1px solid black; padding: 2px;">CTS 9</td> <td style="padding: 2px;">T20</td> <td style="padding: 2px;">R21</td> <td style="padding: 2px;">8</td> <td style="border-left: 1px solid black; padding: 2px;">RS232-CTS</td> </tr> </table> <p style="text-align: center;">Sipex® Vendor P/N: SP232ACT</p>	TXD 11	T11	R10	14	RS232-TXD	RTS 10	T21	R20	7	RS232-RTS	RXD 12	T10	R11	13	RS232-RXD	CTS 9	T20	R21	8	RS232-CTS
TXD 11	T11	R10	14	RS232-TXD																					
RTS 10	T21	R20	7	RS232-RTS																					
RXD 12	T10	R11	13	RS232-RXD																					
CTS 9	T20	R21	8	RS232-CTS																					

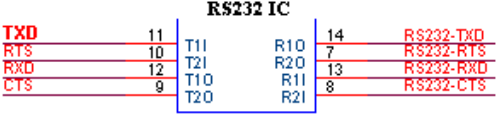
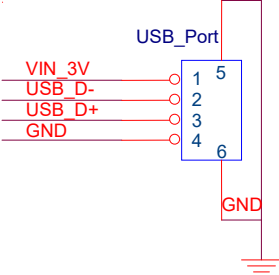
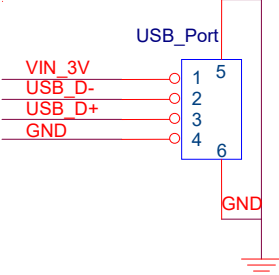
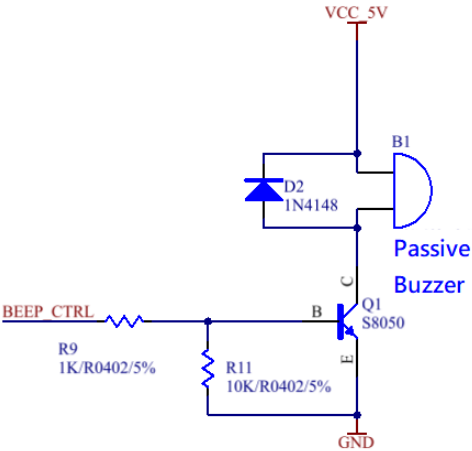
Pin#	UART	USB	I/O	Description	Schematic Example
5	TXD	-----	Output	UART TTL data output.	 <p>Sipex® Vendor P/N: SP232ACT</p>
6	-----	USB_D-	Bidirectional	USB Differential Signal Transmission (USB D-)	
7	-----	USB_D+	Bidirectional	USB Differential Signal Transmission (USB D+)	
8	NC	NC	-----	Floating	
9	Buzzer PWM	Buzzer PWM	Output	Active High: it indicates the status of Power-Up or a successful barcode decoded. PWM controlled signal can be used to drive an external buzzer for a successful barcode decoded (Good Read).	

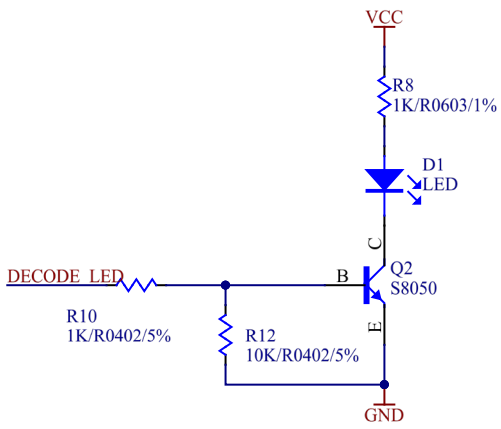
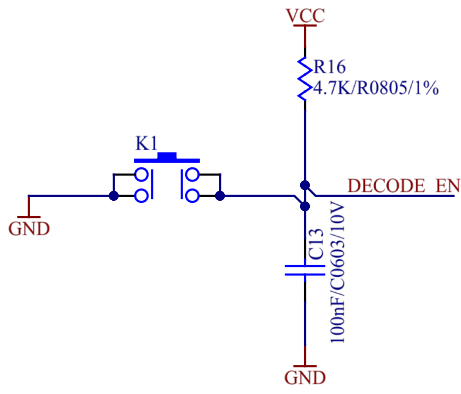
Pin#	UART	USB	I/O	Description	Schematic Example
10	Good Read LED	Good Read LED	Output	When scanning is successful (Good Read), it outputs a high-level pulse, whose load capacity is limited and not enough to driver LED directly. A supporting LED drive circuit is required.	
11	Reset	Reset	Input	Keeping low level for at least 100us and returning to high level or floating state, the scan engine restarts.	
12	Trigger Input	Trigger Input	Input	<p>High: Stop Scanning Low: Start Scanning</p> <p>*Warning: 1. Pull low at power-up will prompt the scan engine into firmware update mode.</p>	 <p>Once trigger is pressed (pull low), scanning operation continues until a barcode is successfully decoded or the trigger is released (pull high). To proceed to the next scanning operation, release (pull high) first and press (pull low) the trigger again. A minimum of 50ms interval is recommended between two trigger signals.</p>

1-2-2. Electric Characteristics

Operating Voltage

T_a=25°C

Symbol	Ratings	Min	Typical	Max	Unit
V _{DD}	Power supply	3.0	3.3	3.6	V
V _{IL}	Input low level	---	---	0.8	
V _{IH}	Input high level	2	---	---	
V _{OL}	Output low level	---	---	0.4	
V _{OH}	Output high level	V _{DD} -0.4	---	---	

Operating Current

T_a=25°C, V_{DD}=3.3V

Ratings	Max	Unit
Standby Current	60	mA
Working Current	110	

2. SPECIFICATIONS

2-1. Introduction

This chapter provides technical specifications of the MT82Ag. Operating method, scanning range and scan angle are also presented.

2-2. Technical Specifications

Optic & Performance	
Light Source	white LED
Aiming	visible red LED linear aimer
Sensor	640 x 480 pixels
Resolution	5mil/ 0.125mm (Code 39)
Field of View	Horizontal 37° Vertical 28°
Scan Angle	Pitch Angle $\pm 55^\circ$ Skew Angle $\pm 55^\circ$ Roll Angle 360°
Print Contrast Ratio	10%
Width of Field	156mm (13Mil Code39)
Typical Depth Of Field (Environment: 800 lux)	5 Mil Code39: 40 ~ 121mm
	13 Mil UPC/EAN: 44 ~ 324mm
	15 Mil QR Code: 28 ~ 209mm
	6.67 Mil PDF417: 36 ~ 116mm
	10 Mil Data Matrix: 22 ~ 121mm
Physical Characteristics	
Dimension	W21.3 x L14.4 x H10.9 mm
Weight	2.6g
Color	Black
Material	Plastic
Connector	12pin ZIF (pitch=0.5mm)
Cable	12pin flex cable (pitch=0.5mm)
Electrical	
Operation Voltage	3.3VDC $\pm 5\%$

Working Current	< 170 mA
Standby Current	< 70 mA
Connectivity	
Interface	UART (TTL-level RS232)
	USB (HID Keyboard)
	USB (Virtual COM)
User Environment	
Operating Temperature	-20°C ~ 60°C
Storage Temperature	-40°C ~ 80°C
Humidity	0% ~ 95%RH (Non-condensing)
Drop Durability	1.5M
Ambient Light	100,000 Lux (Sunlight)
1D Symbologies	UPC-A/ UPC-E EAN-8/ EAN-13 Codabar Matrix 2 of 5 Code 93 Code 128 Code 39 Interleaved 2 of 5 MSI Plessey GS1 DataBar
2D Symbologies	QR Code Micro QR Code PDF417 MicroPDF417 Data Matrix Aztec
Regulatory	
ESD	Functional after 4KV contact, 8KV air discharge <i>(It requires housing that is designed for ESD protection and stray from electric fields.)</i>
EMC	FCC Part 15B Class B, CE EN55032/35
Safety Approval	EN62471 (Exempt Group)
Environmental	WEEE, RoHS 2.0

2-3. Interface

2-3-1. UART Interface

Below are default communication protocols:

Baud rate: 9600

Data Bits: 8

Parity: None

Stop Bit: 1

Handshaking: None

Flow Control Timeout: None

ACK/NAK: OFF

BCC: OFF

Interface Configuration Barcode:



UART

2-3-2. USB HID Interface

Interface Configuration Barcode:



USB HID

2-3-3. USB VCP Interface

Interface Configuration Barcode:



USB VCP

2-4. Operation Method

1. At power-up, the MT82Ag sends the Power-Up signals over Buzzer and LED pins as an indication that the MT82Ag enters **Standby Mode** and is ready for operation.
2. Once the MT82Ag triggered by either hardware or software method, MT82Ag will emit a beam of light which is aligned with the sensor's field of view.
3. The area image sensor captures the image of barcode and produces an analog waveform, which is sampled and analyzed by the decoder firmware running on the MT82Ag.
4. Upon a successful barcode decoded, the MT82Ag turns off the illumination LEDs, sending the Good Read signals over Buzzer and LED pins and transmitting the decoded data to the host.

2-5. Mechanical Dimension

(Unit = mm)

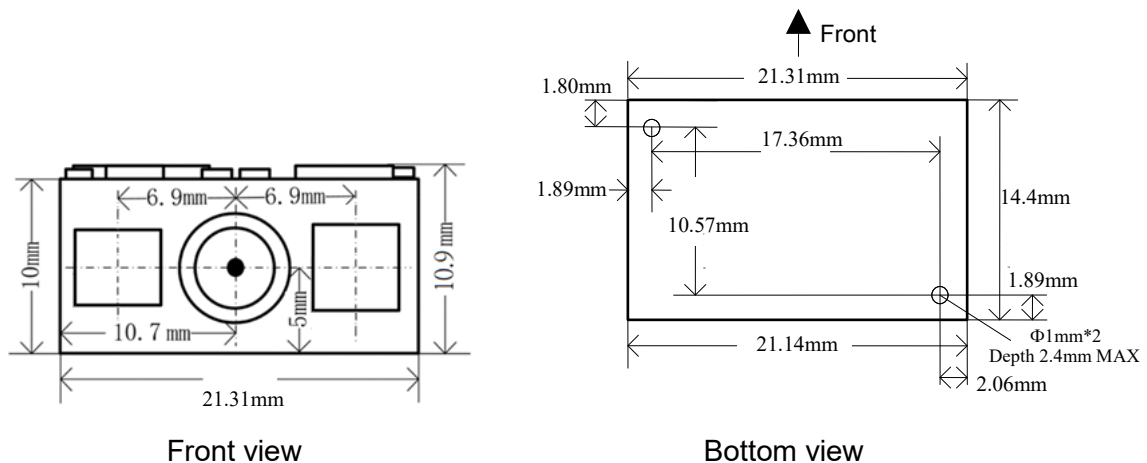

*Note: The width of the front is different from the rear one due to draft angle.

2-6. Connector Specification

Below is the recommended 12-pin 0.5-pitch FPC connector on the host side.

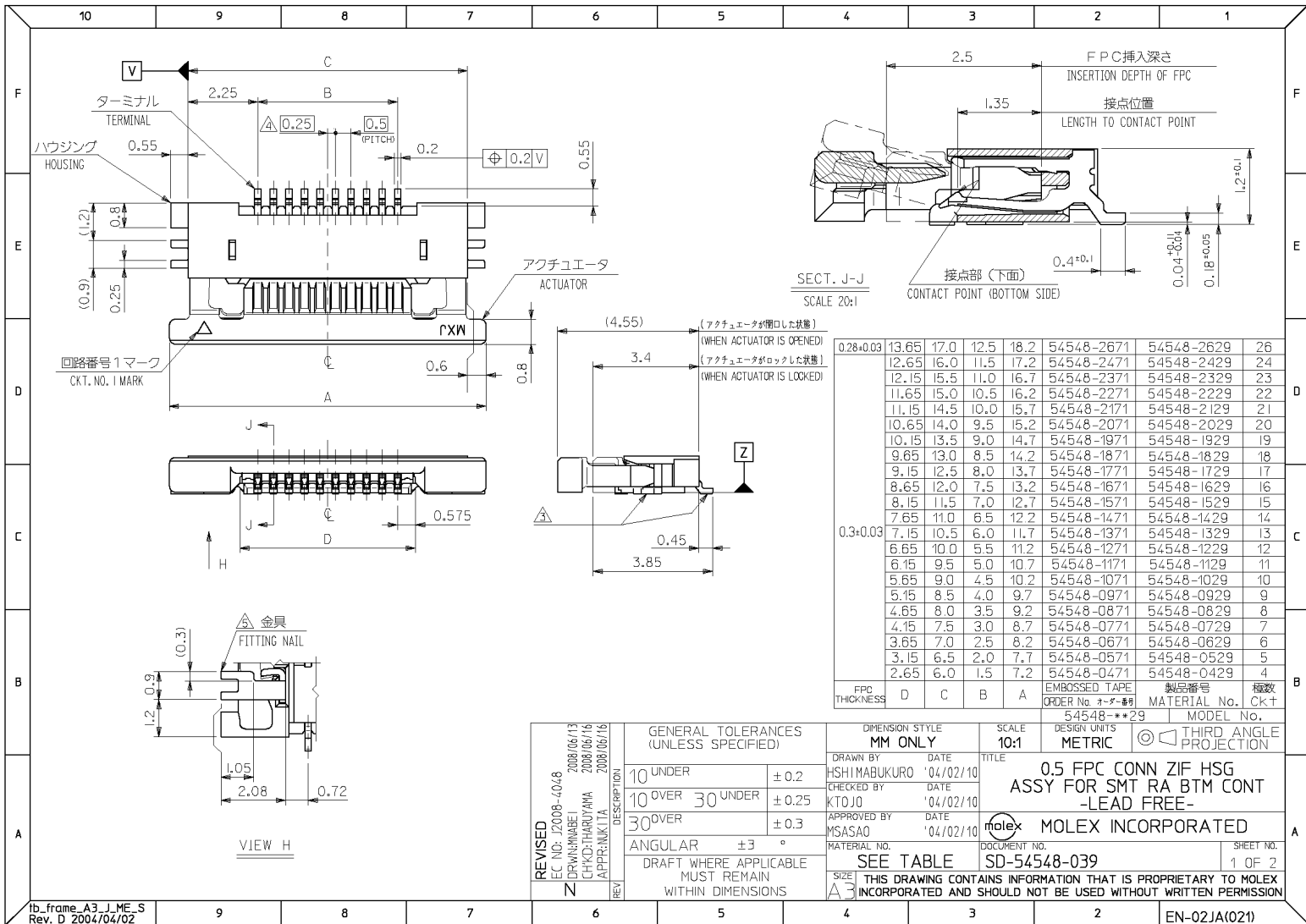

3. INSTALLATION

The scan engine is designed specifically for integration into customer's housing for OEM applications. However, the scan engine's performance will be adversely affected or permanently damaged when mounted into an unsuitable enclosure.

Warning: The limited warranty is void if the following recommendations are not adhered to when mounting the scan engine.

3-1. Electrostatic Discharge Cautions

All scan engines are shipped in ESD protective packaging due to the sensitive nature of the exposed electrical components.

1. ALWAYS use grounding wrist straps and a grounded work area when unpacking and handling the scan engine.
2. Mount the scan engine in a housing that is designed for ESD protection and stray electric fields.

3-2. Mechanical Dimension

When securing the scan engine by utilizing the machine screws:

1. Leave sufficient space to accommodate the maximum size of the scan engine.
2. Do not exceed 1kg-cm (0.86 lb-in) of torque when securing the scan engine to the host.
3. Use safe ESD practices when handling and mounting the scan engine.

3-3. Window Materials

Following are descriptions of three popular window materials:

1. Poly-methyl Methacrylic (PMMA)
2. Allyl Diglycol Carbonate (ADC)
3. Chemically tempered float glass

Cell Cast Acrylic (ASTM: PMMA)

Cell cast Acrylic, or Poly-methyl Methacrylic is fabricated by casting acrylic between two precision sheet of glass. This material has very good optical quality, but is relatively soft and susceptible to attack by chemicals, mechanical stress and UV light. It is strongly recommended to have acrylic hard-coated with Polysiloxane to provide abrasion resistance and protection from environmental factors. Acrylic can be laser-cut into odd shapes and ultrasonically welded.

Cell Cast ADC, Allyl Diglycol Carbonate (ASTM: ADC)

Also known as CR-39™, ADC, a thermal setting plastic widely used for plastic eyeglasses, has excellent chemical and environmental resistance. It also has an inherently moderate surface hardness and therefore does not require hard-coating. This material cannot be ultrasonically welded.

Chemically Tempered Float Glass

Glass is a hard material which provides excellent scratch and abrasion resistance. However, un-annealed glass is brittle. Increased flexibility strength with minimal optical distortion requires chemical tempering. Glass cannot be ultrasonically welded and is difficult to cut into odd shapes.

Property	Description
Spectral Transmission	85% minimum from 635 to 690 nanometers
Thickness	< 1 mm
Coating	Both sides to be anti-reflection coated to provide 1% maximum reflectivity from 635 to 690 nanometers at nominal window tilt angle. An anti-reflection coating can reduce the light that is reflected back to the host case. Coatings will comply with the hardness adherence requirements of MIL-M-13508.

3-4. Window Placement

MT82Ag Side

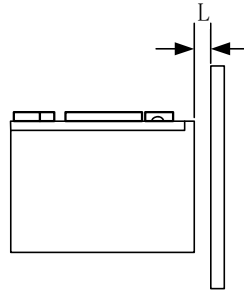

The distance between window and front of MT82Ag should not exceed $L=0.5\text{mm}$
 The thickness of the window should not exceed 1mm

3-5. Window Size

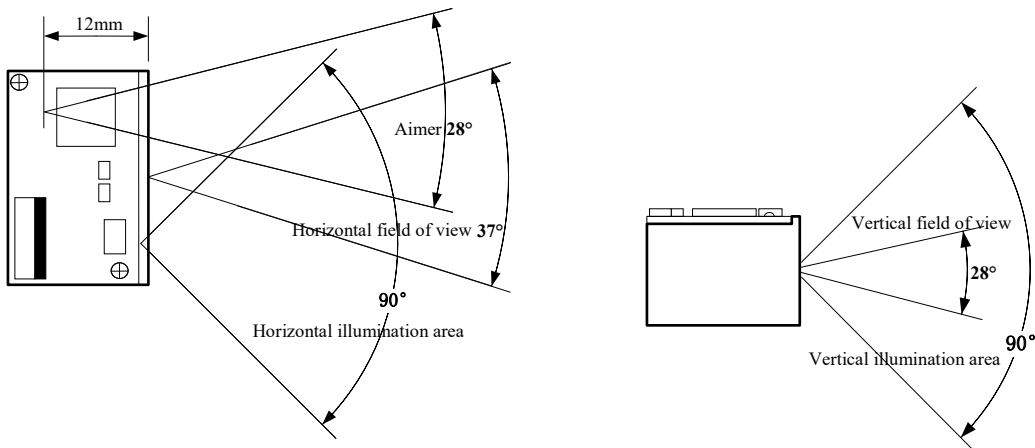

The window size should ensure that field of view is not blocked, and the illumination area should not be blocked as well. For the size of window, please refer to above diagram of each optical area.

3-6. Window Care

In the aspect of window, the performance of MT82Ag will be reduced due to any kind of scratch. Thus, reducing the damage of window, there are few things have to be noticed.

1. Avoid touching the window as much as possible.
2. When cleaning the window surface, please use non-abrasive cleaning cloth, and then gently wipe the host window with the cloth that is already sprayed with glass cleaner.

4. REGULATIONS

The MT82Ag scan engine conforms to the following regulations:

1. Electromagnetic Compliance – CE EN55032/35
2. Electromagnetic Interference – FCC Part 15B Class B
3. Photobiological Safety – EN62471 (Exempt Group)
4. Environmental Regulations – RoHS 2.0, WEEE

5. DEVELOPMENT KIT

MB130 Demo Kit (P/N: [11D0-A020000](#)) includes an MB130 Multi I/O Board (P/N: [9014-3100000](#)) and a micro USB cable. MB130 Multi I/O Board serves as an interface board for MT1 and accelerates the testing and integration with the host system. Please contact your sales representative for ordering information.

MB130 Multi I/O Board (P/N: [9014-3100000](#))

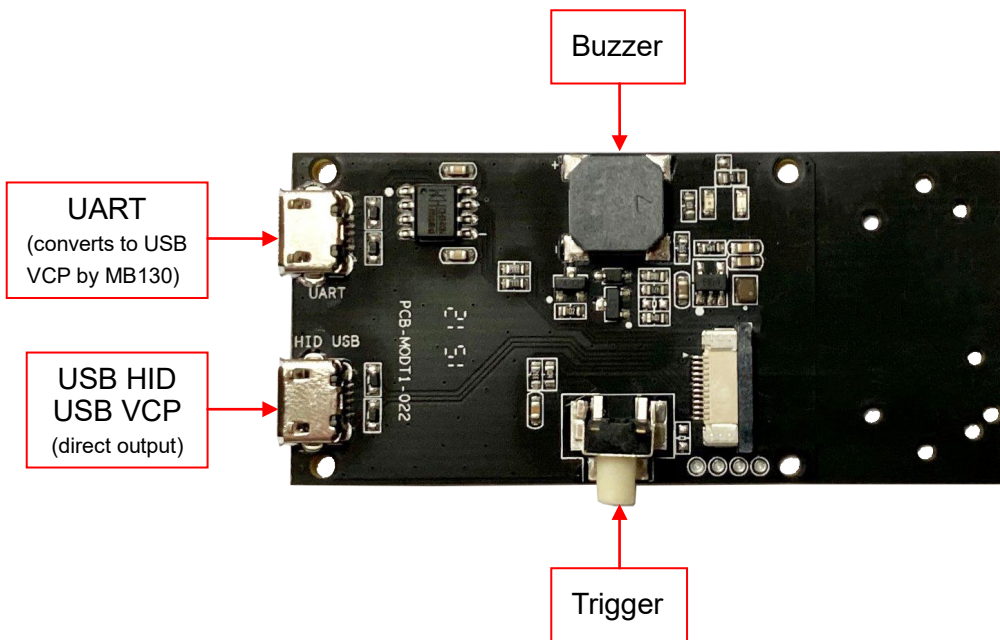

6. PACKAGING

1. **Tray** (size: 24.7 x 13.7 x 2.7cm): Each tray contains 8pcs of [MT82Ag](#).



2. **Box** (size: 25 x 14 x 3.3cm): Each Box contains 1pc of tray, or 8pcs of [MT82Ag](#).



3. **Carton** (size: 30 x 27 x 28cm): Each Carton contains 16pcs of boxes, or 128pcs of [MT82Ag](#).



7. VERSION HISTORY

Rev.	Date	Description	Issued	Checked
0.1	2020.09.15	Preliminary Draft Release	Shaw	Kenji
0.2	2020.09.23	Secondary Draft Revision Revised Model No. to MT82Ag Added Development Kit	Shaw	Kenji
0.3	2020.12.25	Updated Dimension	Shaw	Daniel
0.4	2021.01.20	Added Packaging Updated Typical Depth of Field	Shaw	Kenji
0.5	2021.01.21	Updated Working/Standby Current	Shaw	Kenji
0.6	2021.04.06	Added Aztec Updated Development Kit	Shaw	Kenji
0.7	2021.12.13	Updated Typical D.O.F, Dimension & Regulations	Shaw	Kenji
0.8	2022.09.07	Removed Scan Rate	Shaw	Kenji
0.9	2022.10.06	Updated Development Kit	Shaw	Kenji
1.0	2022.10.23	Updated Field of View, Dimension, Symbologies	Shaw	Kenji
1.1	2023.03.20	Updated Pin Assignment	Shaw	Kenji
1.2	2023.08.22	Updated Mechanical Dimension	Shaw	Alice

Marson Technology Co., Ltd.

9F., 108-3, Minguang Rd., Xindian Dist., New Taipei City, Taiwan

TEL: 886-2-2218-1633

FAX: 886-2-2218-6638

E-mail: info@marson.com.tw

Web: www.marson.com.tw